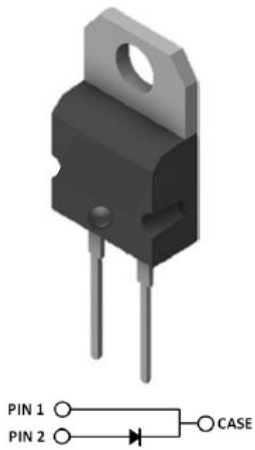

Silicon Carbide Schottky Diode	REVERSE VOLTAGE 650 Volts FORWARD CURRENT 6 Amperes
<p>FEATURES</p> <ul style="list-style-type: none"> • No reverse recovery/No forward recovery • 650-volts Schottky Rectifier • High Frequency Operation • Temperature independent switching behavior • Extremely Fast Switching • Positive Temperature Coefficient on VF <p>MECHANICAL DATA</p> <ul style="list-style-type: none"> • Case: TO-220AC • Polarity: Cathode Band 	<p>TO-220AC</p>  <p>The image shows a 3D perspective view of a TO-220AC package with a metal tab and two leads. Below it is a schematic diagram showing a diode symbol with an arrow pointing from PIN 1 to PIN 2, and a circle labeled CASE.</p>

MAXIMUM RATINGS AND ELECTRICAL CHARACTERISTICS

Ratings at 25 °C ambient temperature unless otherwise specified.
Single phase, half wave, 60Hz, resistive or inductive load.
For capacitive load, derate current by 20%

Characteristics	Symbol	SiC0665ST		Unit
Maximum Repetitive Peak Reverse Voltage	V_{RRM}	650		V
RMS Reverse Voltage	V_{RMS}	650		V
Maximum DC blocking voltage	V_{DC}	650		V
Diode Forward Voltage $I_F=6A$ $T_J=25^{\circ}C$ $T_J=175^{\circ}C$	V_F	Typ.	Max.	V
		1.44	1.8	
		1.73	2.5	
Reverse Current $V_R=650V$ $T_J=25^{\circ}C$ $T_J=175^{\circ}C$	I_R	10	100	μA
		15	200	
Continuous forward current $T_C=25^{\circ}C$ $T_C=135^{\circ}C$ $T_C=150^{\circ}C$	I_F	21.5		A
		10		
		6		
Surge non-repetitive forward current $T_C=25^{\circ}C, t_p=10ms, \text{Half Sine-wave}$	I_{FSM}	42		A
Diode dv/dt ruggedness $V_R=0$	dv/dt	100		V/ns
Total capacitive charge $V_R=650V, di/dt=500A/\mu s, I_F=6A, T_J=25^{\circ}C$	Q_C	16		nC
Total Capacitance $T_J=25^{\circ}C, f=1MHz$ $V_R=0V$ $V_R=200V$ $V_R=400V$	C	400		pF
		40		
		38		
Power dissipation $T_C=25^{\circ}C$ $T_C=110^{\circ}C$	P_{tot}	85		W
		39		
Thermal Resistance, Junction Case	R_{thJC}	1.748		$^{\circ}C/W$
Junction and Storage Temperature Range	T_J, T_{STG}	-55 to +175		$^{\circ}C$

Application

- Switch mode power supply
- Power factor correction
- Solar inverter
- Uninterruptible power supply
- High Efficiency DC/DC Converters
- Motor Drivers

Rating and Characteristic Curves

Fig 1. Typical forward characteristics

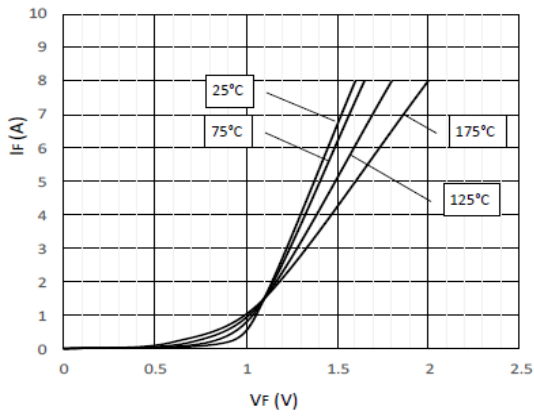

Fig 2. Diode forward current

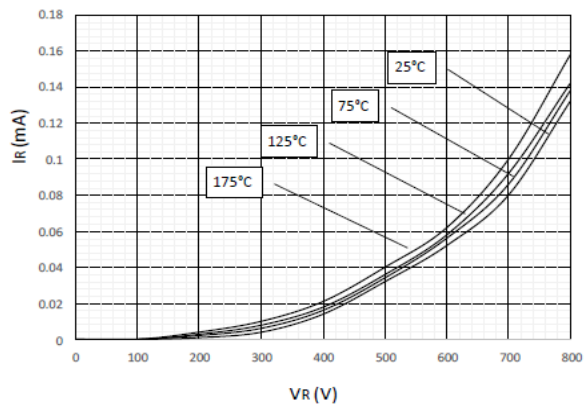

Fig 3. Current Derating

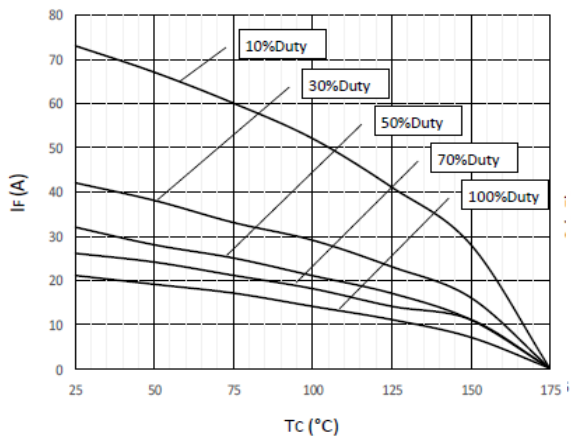
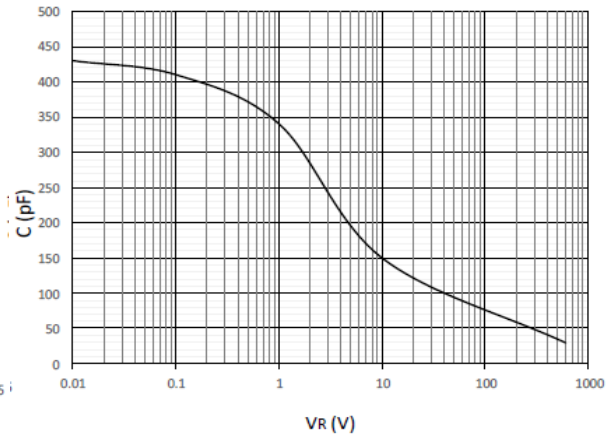
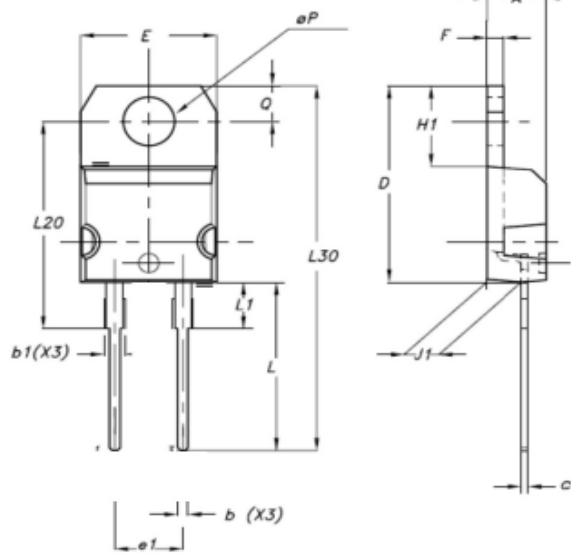

Fig 4. Typical capacitance vs. reverse voltage



Package outline



DIM.	mm			inch		
	MIN.	TYP.	MAX.	MIN.	TYP.	MAX.
A	4.40		4.60	0.173		0.181
b	0.61		0.88	0.024		0.034
b1	1.15		1.70	0.045		0.066
c	0.49		0.70	0.019		0.027
D	15.25		15.75	0.60		0.620
E	10		10.40	0.393		0.409
e1	4.95		5.15	0.194		0.202
F	1.23		1.32	0.048		0.052
H1	6.20		6.60	0.244		0.256
J1	2.40		2.72	0.094		0.107
L	13		14	0.511		0.551
L1	3.50		3.93	0.137		0.154
L20		16.40			0.645	
L30		28.90			1.137	
eP	3.75		3.85	0.147		0.151
Q	2.65		2.95	0.104		0.116

TO-220 Tube outline

